

German Institute of Building Technology (DIBt)

“Translation of original German edition not checked by Deutsches Institut für Bautechnik”

National

A public institution supported jointly by the

Technical

Approval

Approval body for construction products and forms
of construction

Building technology testing institute

A public institution supported jointly by the German
Federation and the German Federal States

Member of EOTA, UEAtc and WFTAO

Date:

4 April 2016

Ref No:

I 25-1.21.8-15/16

“Translation of original German edition not checked by Deutsches Institut für Bautechnik”

Approval No:

Z-21.8-1970

Period of validity:

from: **9 August 2022**

to: **3 August 2027**

Applicant:

TOGE Dübel GmbH & Co. KG

Illesheimer Str. 10

90431 Nuremberg

Germany

Object of the approval:

TOGE TID insulation anchor / Heraklith IDM anchor

The aforementioned object of the approval is hereby granted a National Technical Approval.

This National Technical Approval comprises 7 pages and 3 annexes.

This National Technical approval replaces National Technical Approval No. Z-21.8-1970 of

17 May 2013. The object was first granted a National Technical Approval on 7 August 2012.

I. GENERAL PROVISIONS

- 1 The National Technical Approval verifies the usability of the object of the approval in the meaning of the building regulations of the federal states.
- 2 In so far as the National Technical Approval places requirements on the particular knowledge and experience of the persons entrusted with the provision of construction products and forms of construction according to the federal state regulations corresponding to cl. 17, para. 5, of the *Musterbauordnung* (Model Building Code), it should be noted that this knowledge and experience can also be furnished through equivalent documentation from other Member States of the European Union. This shall also apply to equivalent documentation submitted within the scope of the European Economic Area (EEA) Agreement or other bilateral agreements.
- 3 The National Technical Approval is not a substitute for statutory authorisations, agreements and certificates prescribed for the execution of construction projects.
- 4 The National Technical Approval is issued without prejudice to the rights of third parties, especially private intellectual property rights.
- 5 Without prejudice to more detailed regulations in the “Specific Provisions”, the manufacturer and distributor of the object of the approval must provide users of the object of the approval with copies of the National Technical Approval and point out that the National Technical Approval must be available at the place of use. Upon request, the authorities involved must be provided with copies of the National Technical Approval.
- 6 The National Technical Approval may only be reproduced in whole. Publication of extracts shall require the consent of the Deutsches Institut für Bautechnik (DIBt). Texts and drawings in advertising materials may not contradict the National Technical Approval. Translations of the National Technical Approval must include the remark “Translation of original German edition not checked by Deutsches Institut für Bautechnik”.
- 7 The National Technical Approval is granted until revoked. The provisions of the National Technical Approval can be supplemented and amended at a later date, especially when new technical findings make this necessary.

II. SPECIFIC PROVISIONS

1 Object of the approval and scope of applicability

1.1 Object of the approval

The object of the approval is the TOGE TID insulation anchor / Heraklith IDM anchor in the 8 mm size. The TID/IDM anchor is made from hot-dip galvanised steel or stainless steel.

The TID/IDM anchor is anchored by driving it into a cylindrical drilled hole with a hammer.

Annex 1 shows the TID/IDM anchor in the built-in condition.

1.2 Scope of applicability

The TID/IDM anchor may be anchored in plain and reinforced normal-strength concrete of strength classes from C20/25 (min.) to C50/60 (max.) according to DIN EN 206-1:2001-07 “Concrete – Part 1: Specification, performance, production and conformity”.

The anchor may be used for anchorages that must satisfy fire resistance requirements.

The TID/IDM anchor may only be used for the multiple fixing of insulation boards. The insulation boards must be fixed with at least four anchors per square metre.

The anchor may be anchored in cracked and uncracked concrete.

TOGE insulation anchor type TID S / Heraklith anchor type IDM:

The anchor made from hot-dip galvanised steel may only be used in dry interior conditions (relative humidity < 70%) and in ambient conditions that can be allocated to corrosivity category C1 (very low) or C2 (low) according to DIN EN ISO 12944-2:1998-07.

TOGE insulation anchor type TID R / Heraklith anchor type IDM-R:

The anchor made from stainless steel and stamped “R” may also be used in corrosion resistance class II conditions (interiors and externally, excluding industrial atmospheres and maritime zones or in damp interiors where no aggressive conditions are present) in accordance with National Technical Approval Z-30.3-6 “Products, fasteners and structural components made of stainless steels”.

TOGE insulation anchor type TID R4 / Heraklith anchor type IDM-R4:

The anchor made from stainless steel and stamped “R4” may also be used in corrosion resistance class III conditions (interiors and externally, including industrial atmospheres and maritime zones, or in damp interiors where no especially aggressive conditions are present, with such especially aggressive conditions including, for example, constant, alternating immersion in seawater or in the seawater splash zone, chlorine-laden atmospheres in indoor swimming pools or atmospheres with extreme chemical pollution) in accordance with National Technical Approval Z-30.3-6 “Products, fasteners and structural components made of stainless steels”.

2 Provisions for the construction product

2.1 Properties and composition

The TID/IDM anchor must correspond to the drawings and information contained in the annexes. The material parameters, dimensions and tolerances of the anchor which are not specified in this National Technical Approval must correspond to the information deposited with the DIBt, the certification body and the external auditing body.

2.2 Marking

The packaging, information leaflet or delivery slip for the anchor must be marked by the manufacturer with the German attestation of conformity symbol (Ü mark) according to the attestation of conformity regulations of the German federal states. In addition, the works symbol, approval number and complete designation of the anchor must be specified.

The marking may only be applied once the requirements of section 2.3 “Attestation of conformity” have been fulfilled.

The anchor is designated TID S / IDM (hot-dip galvanised), TID R / IDM-R (stainless steel for CRC¹ II) or TID R4 / IDM-R4 (stainless steel for CRC III).

Every anchor is to be stamped according to annex 2.

2.3 Attestation of conformity

2.3.1 General

Confirmation of the compliance of the anchor with the provisions of this National Technical Approval must be provided for every production plant by means of a certificate of conformity based on in-house production control and regular auditing by an external institute, including initial testing of the anchor in accordance with the following provisions.

Issuing the certificate of conformity and auditing by an external institute, including the product tests to be carried out, requires the manufacturer of the anchor to appoint a certification body and an auditing body, both of which must be accredited for such work.

The declaration that a certificate of conformity has been issued must be indicated by the manufacturer marking the construction products with the German attestation of conformity symbol (Ü mark) and including information about the intended purpose.

The certification body must provide the DIBt with a copy of the certificate of conformity issued by that body.

The DIBt must also be provided with a copy of the report on initial testing for information purposes.

2.3.2 In-house production control

In-house production control is to be set up and carried out at every production plant. In-house production control is understood to be continual monitoring of production by the manufacturer’s personnel in order to guarantee that the construction products manufactured comply with the provisions of this National Technical Approval.

The testing plan deposited with the DIBt and the external auditing body shall regulate the scope, nature and frequency of the in-house production control measures.

The results of in-house production control are to be recorded and evaluated. The records must include the following details at least:

- the designation of the construction product or the raw material and the components;
- the type of inspection or testing;
- the dates of production and testing of the construction product or the raw material or the components;

¹ CRC = corrosion resistance class corresponding to National Technical Approval Z-30.3-6 “Products, fasteners and structural components made of stainless steels”.

- the results of inspections and tests and, if applicable, a comparison with the requirements;
- the signature of the person responsible for in-house production control.

The records are to be retained for at least five years and made available to the external auditing body appointed to carry out auditing work. Upon request, they are to be made available to the DIBt and the most senior building authority responsible.

If the results of tests are unsatisfactory, the manufacturer must take the necessary measures to rectify the defects without delay. Construction products that do not comply with the requirements are to be marked in such a way that they cannot be mistaken for compliant products. After rectifying the defects, the test involved must be repeated without delay, in so far as this is technically possible and is required for verifying rectification of the defects.

2.3.3 Auditing by an external body

The in-house production control in every anchor production plant is to be audited regularly, but at least twice annually, by an external body.

External auditing must include initial testing of the anchor and the taking of samples for spot checks. The sampling and tests are in all cases the responsibility of the accredited auditing body.

The testing plan deposited with the DIBt and the external auditing body shall regulate the scope, nature and frequency of the external auditing measures.

The results of certification and external auditing are to be retained for at least five years. Upon request, the certification or auditing body shall make them available to the DIBt and the most senior building authority responsible.

3 Provisions for design and dimensioning

3.1 Design

The anchorages are to be designed according to engineering principles. Verifiable calculations and drawings must be produced taking into account the loads to be anchored.

The TID/IDM anchor may only be used for the multiple fixing of insulation boards. The insulation boards must be fixed with at least four anchors per square metre. Only anchors with additional discs may be used in insulation boards without a hard facing and in joints between insulation boards.

The length of the anchor must be selected depending on the thickness of the insulation such that the minimum insertion depth complies with annex 3, table 2.

The drawings must include the exact positions of the TID/IDM anchors.

3.2 Dimensioning

3.2.1 General

The direct local force transfer to the concrete has been verified. It is necessary to verify that the loads to be anchored are transferred further within the building element.

The load-carrying capacity of the anchor in the insulation board is not the object of this approval.

It is necessary to consider additional stresses due to restrained deformation (e.g. in the case of temperature fluctuations) which can ensue in the anchor, in the attached component or in the building element in which the anchor is installed.

The building element thickness and the minimum edge distances and centre-to-centre spacings of the anchor may not be less than the values given in annex 3.

It is necessary to verify that the design value of the action F_{Ed} does not exceed the design value of the resistance F_{Rd} : $F_{Ed} \leq F_{Rd}$

The design values of the resistance are valid for all loading directions irrespective of the type of failure. The resistances are specified in annex 3.

3.2.2 Design for exposure to fire

The characteristic anchor parameters relevant for exposure to fire are specified in annex 3, table 3. Verification is valid for a component exposed to fire on one side. In the case of exposure to fire on more than one side, the verification is only valid for an anchor edge distance $c \geq 300$ mm.

4 Provisions for installation

4.1 General

The installation of the anchor is to be carried out in accordance with the drawings produced according to section 3.1.

Follow the installation instructions given in annex 1.

4.2 Drilling and cleaning out the hole

The position of the hole must be coordinated with the reinforcement in such a way that damage to the reinforcement is avoided.

The hole is to be drilled perpendicular to the concrete surface using a carbide-tipped masonry drill bit. Carbide-tipped masonry drill bits must comply with the information given in the leaflet on “characteristic values, requirements and tests for masonry drill bits with carbide cutting body which are used for the manufacture of drilled holes for anchoring” (Jan 2002 ed.) published by the DIBt. Compliance with the drill bit parameters must be verified according to section 5 of the leaflet.

Nominal drill bit diameter, cutting edge diameter and drilled hole depth must correspond to the values given in annex 3. Drilling dust and debris must be removed from the hole.

If a hole is drilled incorrectly, the spacing between this and a new hole must be at least two times the depth of the incorrectly drilled hole.

4.3 Inserting the anchor

The TID/IDM anchor may only be driven through the insulation board and anchored in the concrete building element with the aid of a suitable tool (e.g. hammer) according to annex 1. The insulation boards are to be firmly pressed against the surface of the concrete with the aid of discs, and additional discs if necessary, according to annex 2.

4.4 Checking the installation

When installing the anchor, the contractor entrusted with the work or the site manager appointed by such contractor or a competent representative of the site manager must be present on the building site. He/she must ensure that the work is carried out properly and must compile records of the installation of the anchor.

The records must be available during the construction time on the building site and, upon request, must be made available to persons appointed to carry out inspections. Like the delivery slips, after conclusion of the work, they must be retained by the company for at least five years.

Andreas Kummerow

Head of Department

Certified

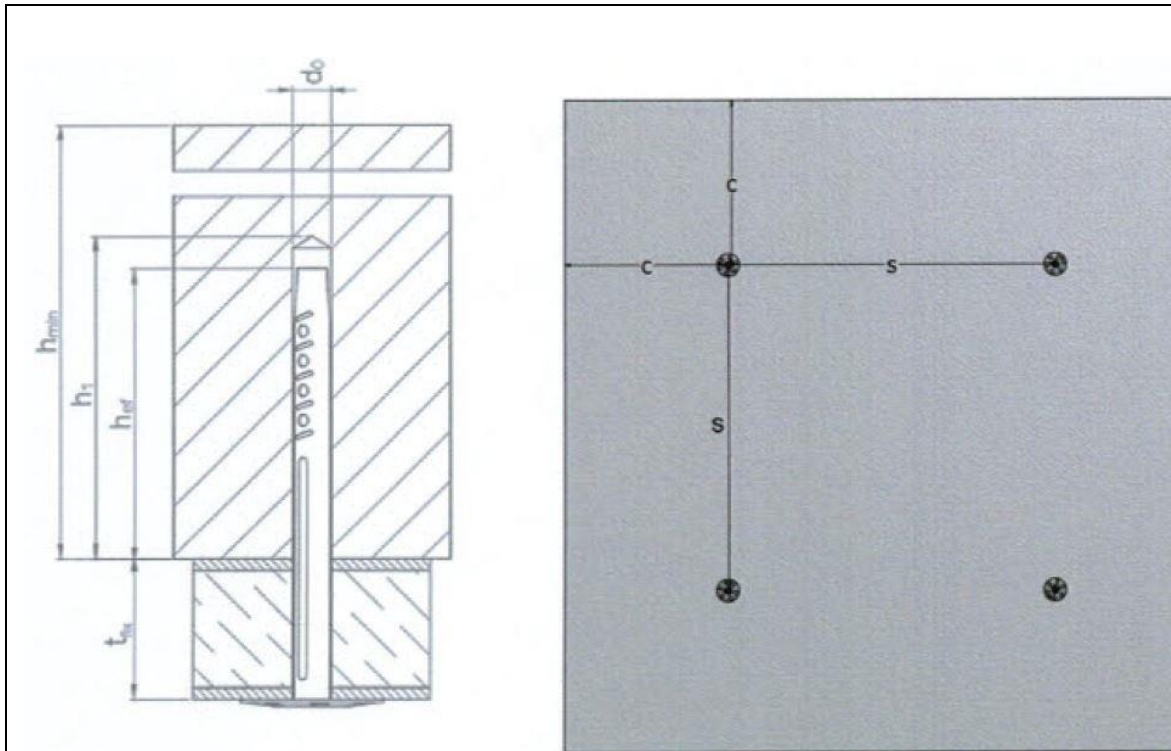

Number of anchors: at least four per square metre of insulation board

Installation instructions

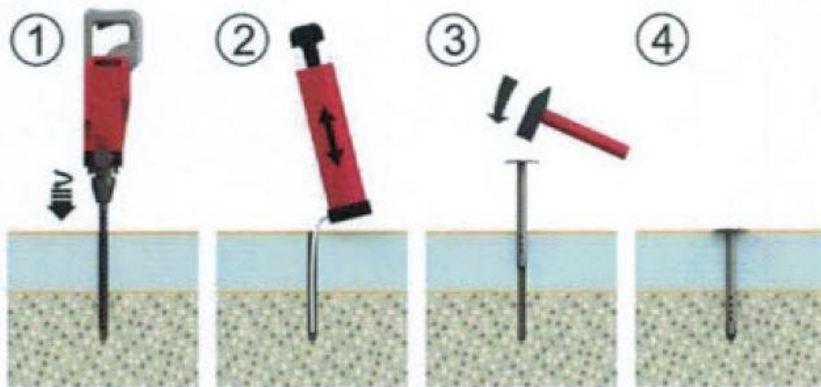

- 1) Drill the hole through the insulation board.
- 2) Clean out the hole from the bottom up.
- 3) Drive the insulation fastener through the insulation board using a hammer.
- 4) The anchor disc must make full contact with the insulation board.

TID insulation anchor	Annex 1
Product and installed condition, sketch of installation, installation instructions	

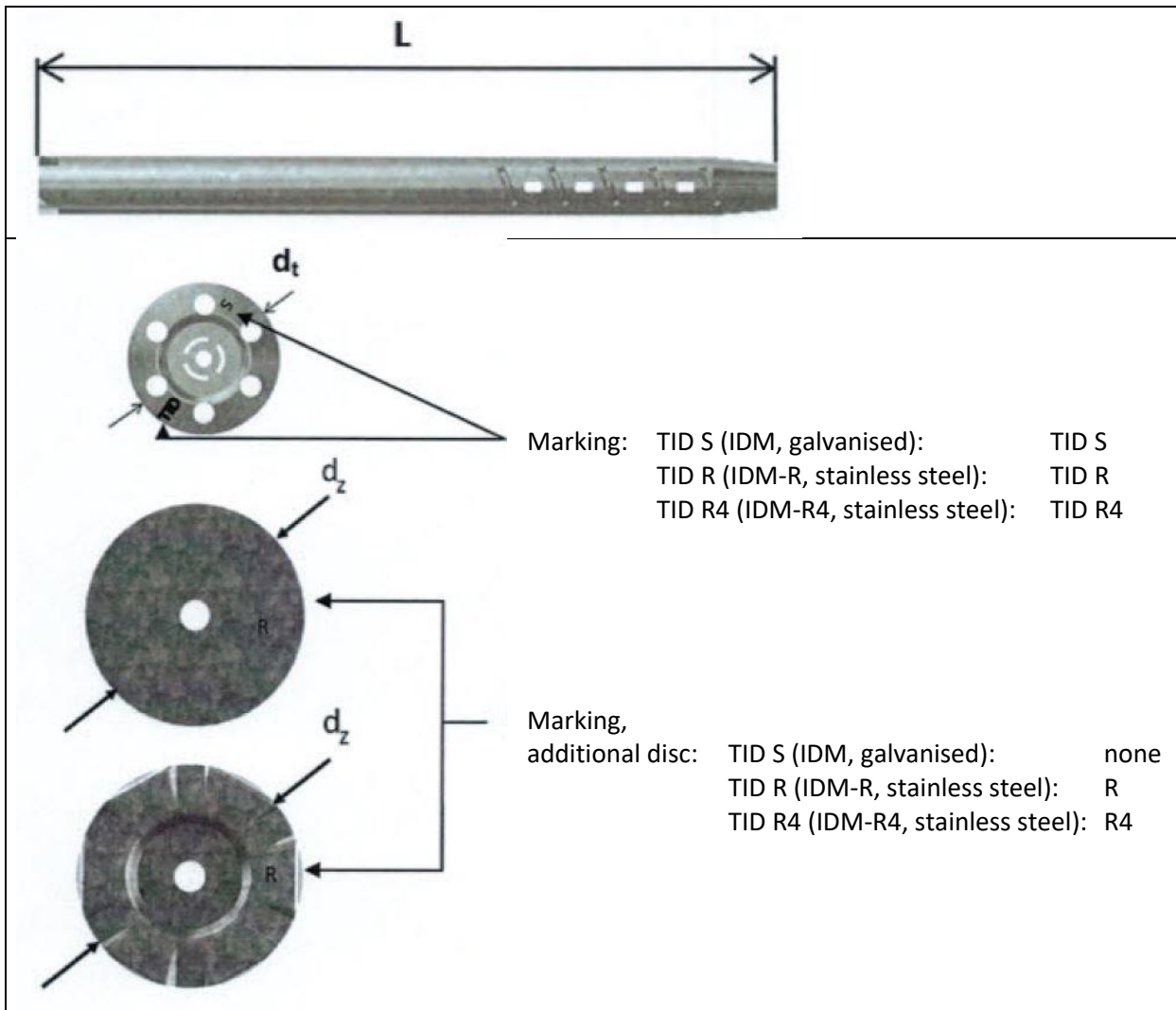

Table 1: Anchor dimensions and materials

Anchor designation			TID (IDM)		
			S	R	R4
Anchor length	$L \geq$	mm	50		
	$L \leq$		300		
Sleeve diameter	d_n	mm	9		
Disc diameter	d_t	mm	35		
Diameter of additional disc	d_z	mm	80		
Material			Steel, hot-dip galvanised, DIN EN 10346:2015-10	Stainless steel according to CRC II ¹⁾	Stainless steel according to CRC III ¹⁾

¹⁾ Corrosion resistance class according to National Technical Approval Z-30.3-6

TID insulation anchor	Annex 2
Anchor dimensions and materials	

Table 2: Installation parameters, minimum building element thickness and design resistances in all loading directions and for all types of failure

Anchor designation			TID (IDM) S / R / R4
Nominal drill diameter	d_0	[mm]	8.0
Drill cutter diameter	$d_{cut} \leq$	[mm]	8.45
Depth of drilled hole	$h_1 \geq$	[mm]	45
Anchorage depth	$h_{ef} \geq$	[mm]	40
Min. building element thickness	h_{min}	[mm]	80
Min. edge distance	c_{min}	[mm]	60
Min. centre-to-centre spacing	s_{min}	[mm]	120
Design resistance in cracked and uncracked concrete of classes C20/25 to C50/60	$F_{Rd}^{1)}$	[kN]	0.1

¹⁾ Permissible load, perm $F = F_{Rd} / \gamma_F$, with $\gamma_F = 1.35$

Table 3: Characteristic values for fire exposure in cracked and uncracked concrete of classes C20/25 to C50/60 for TOGE TID insulation anchor

Anchor designation				TID (IDm) S / R / R4
Fire resistance class				
R 30	Characteristic load-carrying capacity	$F_{Rk,fi30}^{1)}$	[kN]	0.07
R 60	Characteristic load-carrying capacity	$F_{Rk,fi60}^{1)}$	[kN]	0.07
R 90	Characteristic load-carrying capacity	$F_{Rk,fi90}^{1)}$	[kN]	0.07
R 120	Characteristic load-carrying capacity	$F_{Rk,fi120}^{1)}$	[kN]	0.06
R 30 to R 120	Centre-to-centre spacing	$s_{min,fi}$	[mm]	160
	Edge distance	$c_{min,fi}^{2)}$		80

¹⁾ For fire exposure, the partial safety factor for load-carrying capacity is $\gamma_{M,fi} = 1.0$.

²⁾ In the case of exposure to fire from more than one side, the edge distance must be ≥ 300 mm.

TID insulation anchor	Annex 3
Installation parameters, minimum building element thickness and design resistances	