



General design type approval

Zulassungsstelle für Bauprodukte und Bauarten Bautechnisches Prüfamt

Eine vom Bund und den Ländern
gemeinsam getragene Anstalt des öffentlichen Rechts
Mitglied der EOTA, der UEAtc und der WFTAO

Date
16/01/2020

Reference
125-1.21.8-81/19

Number
Z-21.8-2115

Period of validity
from: 16 January 2020
until: 16 January 2025

Requested by:
TOGE Dübel GmbH & Co. KG
Illesheimer Straße 10
90431 Nuremberg
Germany

Subject of this notification
**TOGE TSM high performance concrete screw for temporary fastening of
construction site equipment**

The regulation item specified above is hereby granted general building control approval. This notification comprises five pages and six appendices.



I GENERAL PROVISIONS

- 1 The general design type approval verifies the applicability of the regulation item in the sense of the state building regulations.
- 2 This notification does not replace the approvals, consents and certifications legally required for implementing building projects.
- 3 This notification is issued irrespective of the rights of third parties, in particular private intellectual property rights.
- 4 The user of the regulation item must be provided with copies of this notification, irrespective of further provisions in the "Special provisions". In addition, the user of the regulation item must be informed that this notification must be available at the place of application. On request, the authorities involved must also be provided with copies.
- 5 This notification may only be copied in its entirety. Publication of excerpts requires approval from the Deutsches Institut für Bautechnik. Text and drawings in advertising brochures must not contradict this notification. Translations must contain the note "Translation of the German original, not verified by the Deutsches Institut für Bautechnik".
- 6 This notification is issued subject to revocation. The provisions may be supplemented and changed subsequently, in particular if required based on new technical findings.
- 7 This notification refers to the information and documents provided by the requester concerning the regulation item during the approval process. This notification does not cover any changes to this information on which this notification is based and must be disclosed to the Deutsches Institut für Bautechnik without delay.
- 8 The general design type approval covered by this notification is also accepted as the general building regulation approval for the design type.

II SPECIAL PROVISIONS

1 Regulation item and scope

1.1 Regulation item

This general design type approval governs the temporary anchoring in concrete using the TSM high performance concrete screw (referred to as the “bolt” in the following) as per the European technical evaluation ETA-15/0514 dated 28 May 2019.

The screw is anchored by screwing it into a pre-drilled, cylindrical hole. The special thread of the screw cuts a thread into the anchoring substrate. Anchoring is achieved by positive locking of the special thread in the concrete.

Appendix 1 shows the anchoring.

1.2 Scope

The anchoring may be used in reinforced and non-reinforced standard concrete of minimum grade C20/25 and maximum grade C50/60 as per DIN EN 206-1:2001-07 “Concrete - Part 1: Specification, performance, production and conformity” as well as in cracked and uncracked concrete.

The anchoring may be installed and stressed before the concrete reaches the required characteristic compressive strength, with verification as per section 2.3.1.

The anchoring may only be used for temporary fastening of construction site equipment, e.g. construction supports, fall protection and scaffolding.

The screw may be reused in new holes after removal. A drilled hole must not be reused after a screw is removed. Whether the bolt can be reused must be determined before each use with a visual check and using a ring gauge as per section 2.3.3. Installed screw must be checked for visible damage (e.g. due to corrosion) on a regular basis.

The screw is suitable for temporary use indoors and outdoors.

2 Provisions for planning, dimensions and installation

2.1 Planning

The anchorings must be planned using the rules of engineering. Verifiable calculations and design drawings must be produced, taking into account the loads to be anchored.

The design drawings must contain the exact position of the screw as well as its size and insertion depth.

2.2 Dimensions

The direct local force application in the concrete has been verified. The further transmission of the loads to be anchored in the element must be verified.

Additional loads which can arise from restricted changes in shape (e.g. due to temperature changes) in the screw, in the element to be connected or in the element in which the screw is anchored must be taken into account.

The minimum distances of the screw (centre distance, edge distance) and the thickness of the concrete elements as per Appendix 5 must not be fallen short of.

It must be verified that the design value of the impact F_{Ed} does not exceed the design value of the resistance F_{Rd} :

$$F_{Ed} \leq F_{Rd}$$

The design values of the resistance apply to all load directions (except crosswise to the construction support axis) depend on the failure type. The resistance values are stated in Appendix 6, table 5, as a function of the bolt size, insertion depth and concrete strength $f_{ck,cube}$.

2.3 Installation

2.3.1 General information

The screw to be anchored must be installed as per the design drawings prepared in accordance with section 2.1.

The screw may be used in fresh concrete before it has reached the characteristic compressive strength of the concrete $f_{ck,cube}$. In this case, the compressive strength of the concrete must have reached a value of $f_{c,cube} \geq 10$ N/mm.

2.3.2 Producing and cleaning the drilled hole

The position of the drilled hole must be coordinated so as to avoid damage to the reinforcement.

The hole must be drilled at a right angle to the concrete surface using a hammer drill, hollow drill or diamond drill.

The TCT masonry drill must additionally comply with the information in the information leaflet from the Institut für Bautechnik on "Kennwerte, Anforderungen und Prüfungen von Mauerbohrern mit Schneidkörpern aus Hartmetall, die zur Herstellung der Bohrlöcher von Dübelverankerungen verwendet werden" (Characteristic values, requirements and tests for masonry drills with tungsten carbide tipped cutting elements which are used for producing holes intended for bolt anchoring) in the version dated January 2002. Compliance with the characteristic values of the drill must be verified with an acceptance test certificate 3.2 (DIN EN 10204) or with a test mark from the Prüfungsgemeinschaft Mauerbohrer e.V., Remscheid (see information leaflet, section 5).

Diameter of the drilled hole, diameter of the drill and depth of the drilled hole must correspond to the values in Appendix 5. The drilling dust must be removed from the drilled hole.

If a faulty hole is drilled, a new hole must be drilled at a distance of at least twice the depth of the faulty hole.

2.3.3 Inserting the screw

The screw is intended only for temporary use in a single drilled hole. After removal, the screw can be reused in other drilled holes. However, the screw must not be installed in the same hole twice.

Before each reuse, the wear on the thread must be checked with an appropriate ring gauge as per Appendix 3. The screw may only be reused if no more than 3 turns of the thread can enter into the ring gauge. Screw with visible damage, e.g. caused by corrosion wear, must not be reused as a rule.

The screw can be installed with an impulse wrench with tangential impact.

To avoid the screw spinning, the wrench must be equipped with a power output in the upper range with an automatic shut-off device, e.g. using the depth stop.

The screw is anchored correctly when

- the base plate (attachment part) to be fastened is screwed against the concrete across the entire surface without any intermediate layer
- the head of the screw rests on the base plate
- slight further turning of the screw is not possible
- the setting depth h_{nom} is observed

2.3.4 Checking installation

The company owner tasked with the anchoring, the construction site manager commissioned by them or a competent representative of the construction site manager must be present at the construction site during installation of the screws. They must ensure correct execution of the work.

During installation of the anchors, the construction site manager or their representative must document the verification of the established compressive strength of the concrete as per section 2.3.1 and the correct installation of the screw. The construction site manager or their representative must regularly check the installed screw as per section 2.3.3. The results must be documented.

These documents must be available at the construction site during the construction period and must be submitted to the person responsible for verification on request. As well as the delivery notes, these documents must be retained by the company for at least 5 years after completion of the work.

Beatrix Wittstock
Head of Division

Installed product

TOGE TSM high performance concrete screw

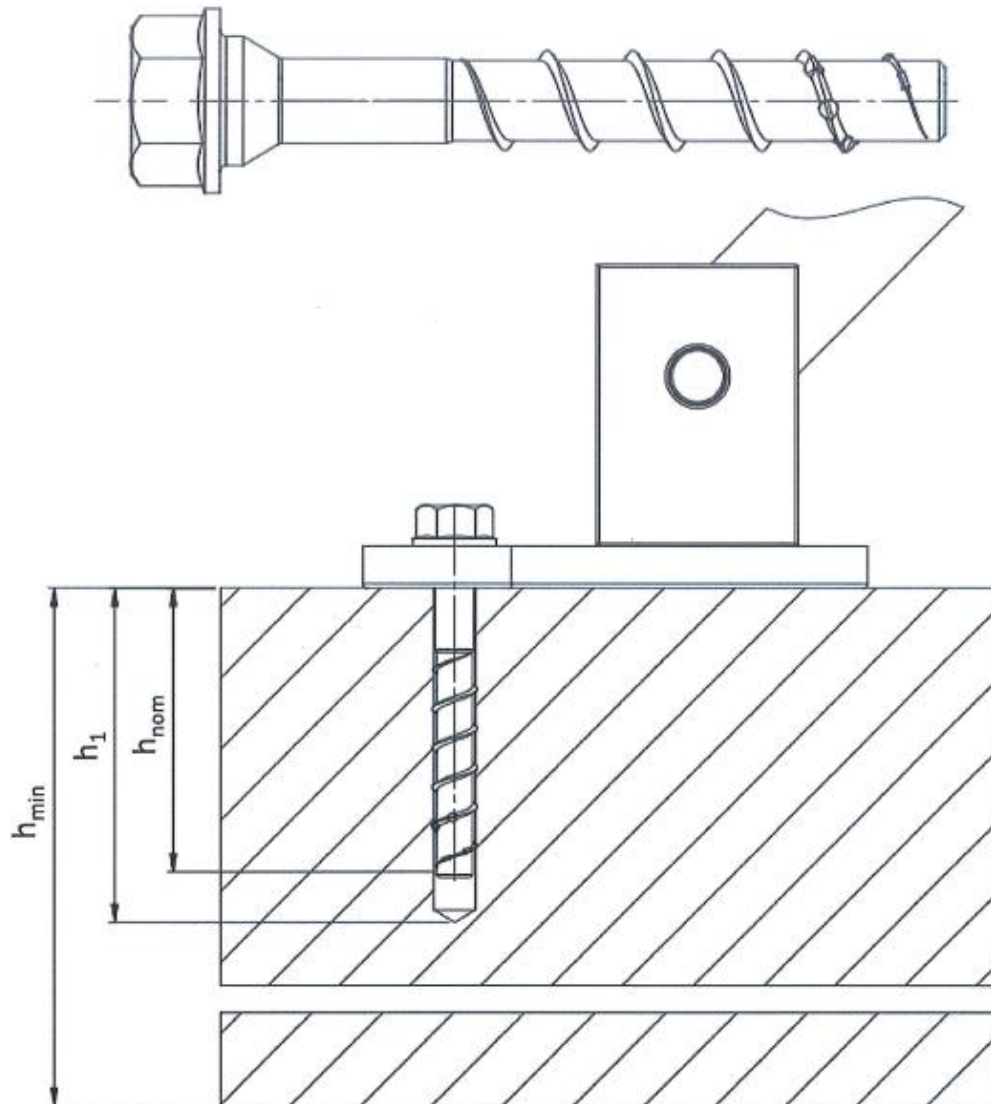

TOGE TSM high performance concrete screws

Product description
Installed product

Annex 1

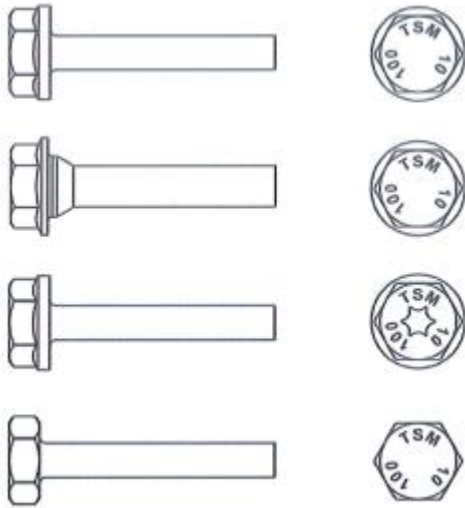

1. Version with hexagon head, attached washer, e.g. TSM 8x80 WAF13 VZ 40
2. Version with hexagon head and flange, e.g. TSM 8x80 WAF13 VZ 40
3. Version with hexagon head, attached washer and TORX, e.g. TSM 8x80 WAF13
4. Version with hexagon head, e.g. TSM 8x80 WAF13 VZ OS

Table 1: Material

Part	Designation	Material
All versions	TSM high performance	Steel DIN EN 10263-4:2018-02 electrogalvanised as per DIN EN ISO 4042:2018-11 or zinc-flake coated as per DIN EN ISO 10683:2018-11 ($\geq 5 \mu\text{m}$)

Marking:

TSM high performance

Screw type: TSM
 Screw diameter: 10
 Screw length: 100



TOGE TSM high performance concrete screws

Product description
 Versions, stamping and materials

Annex 2

Table 2: Dimensions

Screw size		10	12	14	
Screw length	$\geq L$	[mm]	80	80	80
	$\leq L$	[mm]	310	310	310
Core diameter	d_k	[mm]	8.8	10.8	12.8
Outer thread diameter	d_s	[mm]	12.6	14.6	16.6
Shaft diameter	d_1	[mm]	9.9	11.7	13.7
Ring gauge inner diameter	d_3	[mm]	12	14	16

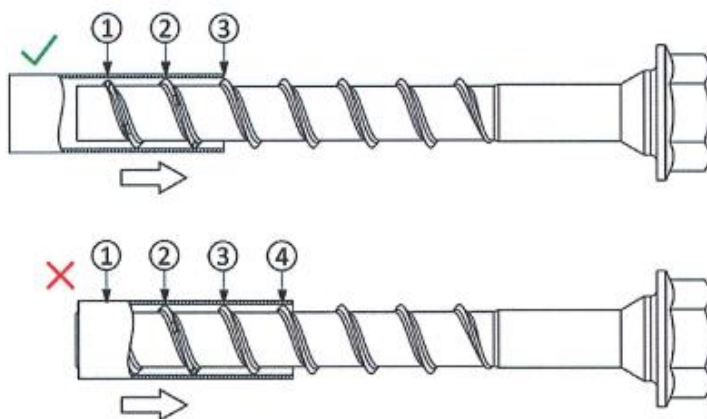
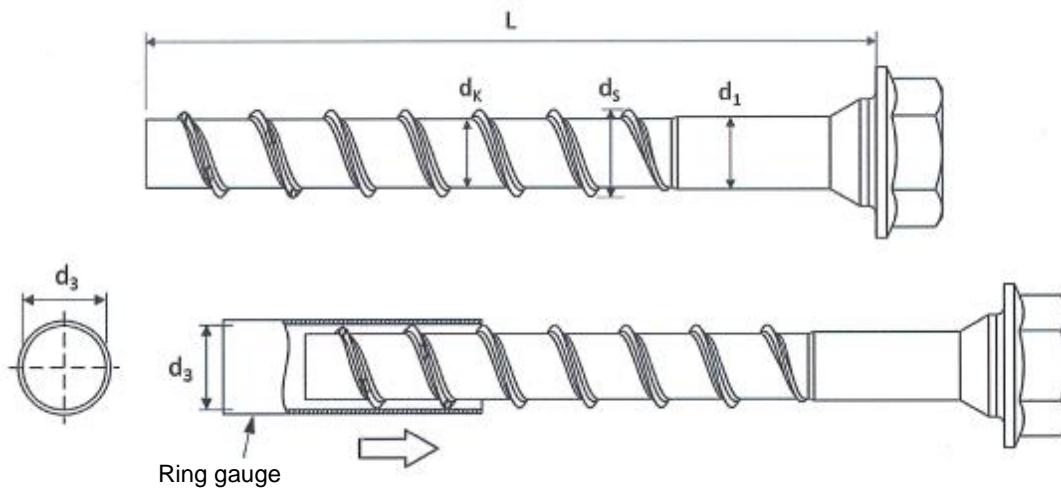

Before each reuse, the degree of wear on the thread must be checked with an appropriate ring gauge.

The concrete screw may only be reused if no more than 3 turns of the thread can enter into the ring gauge.

Screws with visible damage, e.g. caused by corrosion wear, must not be reused as a rule.

TOGE TSM high performance concrete screw

Product description
 Dimensions and application of the ring gauge

Annex 3

Installation instructions

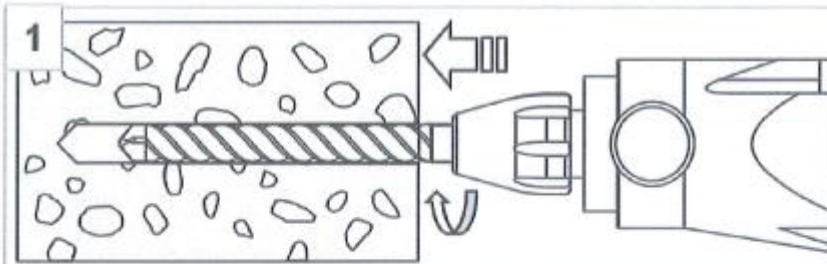

Drill a hole with a hammer drill or hollow drill

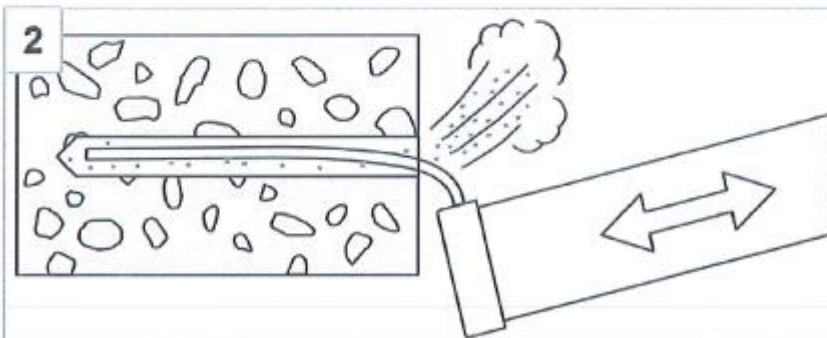

Clean the drilled hole by blasting or vacuuming

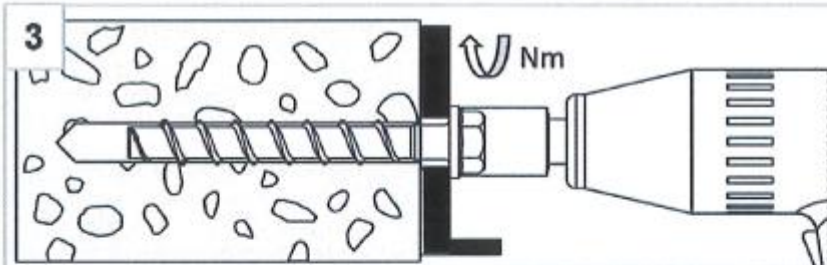

Screw in the screw with an impact screw driver or ratchet wrench

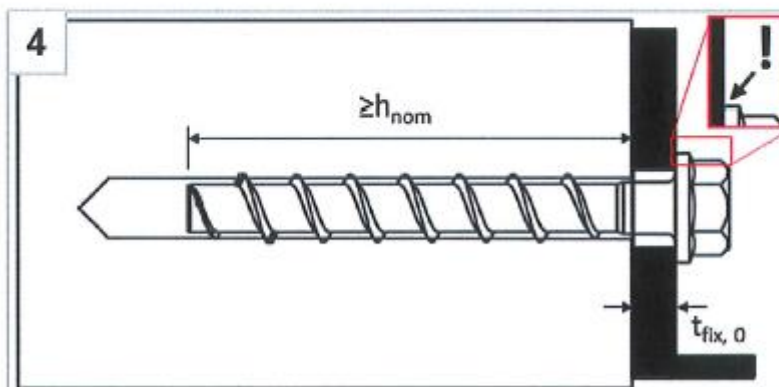

The screw head must rest on the attachment part and must not be damaged.

Note:

If using a hollow drill, the drilled hole does not require cleaning.

TOGE TSM high performance concrete screws

Installation parameters
 Installation instructions

Annex 4

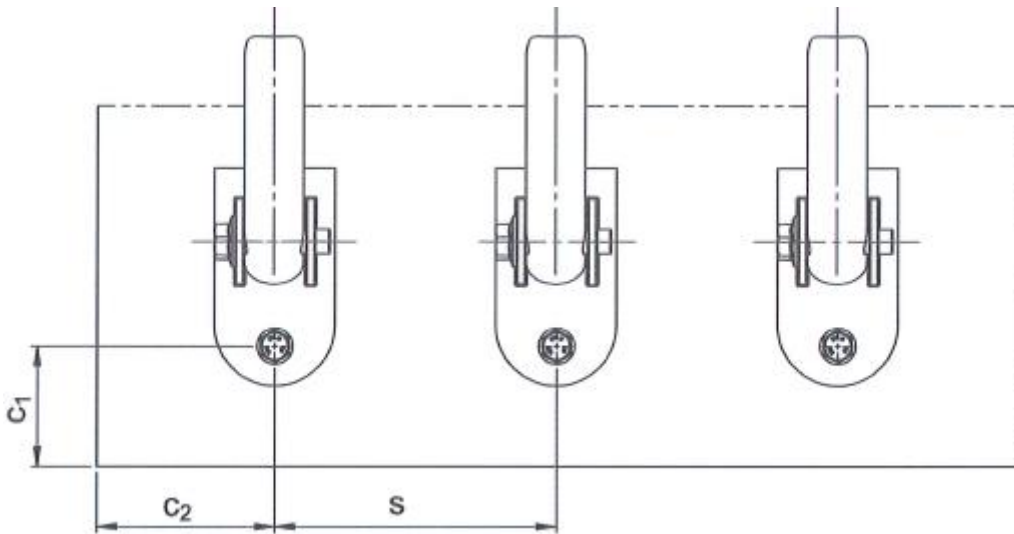

Table 3: Installation parameters

Screw size			10	12		14		
Nominal installation depth	h_{nom}		h_{nom1}	h_{nom1}	h_{nom2}	h_{nom1}	h_{nom2}	h_{nom3}
	[mm]		75	75	90	75	90	115
Nominal drilled hole diameter	D_0	[mm]	10	12		14		
Drill bit diameter	$d_{cut} \leq$	[mm]	10.45	12.5		14.5		
Drilled hole depth	$h_i \geq$	[mm]	85	85	100	85	100	125
Tangential impact wrench		[Nm]	Max. rated torque as per manufacturer's information					
			400	650		650		

Table 4: Minimum component thickness, minimum centre distance and edge distance

Screw size			10	12		14			
Nominal installation depth	h_{nom}		h_{nom1}	h_{nom1}	h_{nom2}	h_{nom1}	h_{nom2}	h_{nom3}	
	[mm]		75	75	90	75	90	115	
Minimum component thickness	h_{min}	[mm]	150	150	195	150	195	200	225
Minimum centre distance	s	[mm]	320	320	390	320	390	500	500
Minimum edge distance in load direction	C_1	[mm]	105	105	130	105	130	165	165
Minimum edge distance crosswise to load direction	C_2	[mm]	160	160	195	160	195	250	250

TOGE TSM high performance concrete screw

Performance characteristics

Minimum component thickness, minimum centre distance and edge distance

Annex 5

Table 5: Design resistances in cracked and uncracked concrete C20/25 to C50/60 in all load directions

Screw size		10		12		14			
Nominal installation depth		h_{nom}	h_{nom1}	h_{nom1}	h_{nom2}	h_{nom1}	h_{nom2}	h_{nom3}	
		[mm]	75	75	90	75	90	115	
Design resistance in concrete with compressive strength $f_{ck,cube} \geq 10$ [N/ mm ²]	F_{Rd}	[kN]	6	6	12	6	12	15	17
Design resistance in concrete with compressive strength $f_{ck,cube} \geq 15$ [N/ mm ²]	F_{Rd}	[kN]	7	7	13	7	13	18	21
Design resistance in concrete with compressive strength $f_{ck,cube} \geq 20$ [N/ mm ²]	F_{Rd}	[kN]	8	8	14	8	14	20	24

TOGE TSM high performance concrete screws

Performance characteristics
 Characteristic load rating

Annex 6